



**[DIY]
[KIT]**

XT-582 OUTBACK (AU\$ EXPORT)

Tundra version shown with Merlin wing.

AIRBORNE DIY MICROLIGHT KITS

Airborne's new kit is the proven XT 582 Outback model with open cockpit, tundra tyres, disk brakes and the Rotax 582 engine (owner supplied).

- The full kit consists of five stages - available independently.

1 → 2 → 3 → 4 → 5 →



- Kit components will be supplied at a high level of manufacture, with mainly assembly, rather than manufacture, required to complete the aircraft – you do not need a machine shop to build your own trike! (Note: Minor welding required for exhaust system).
- Buying stages will provide everything necessary to make a standard XT582 trike, including engine fitout components & instructions for purchasing the correct 582 powerplant from Rotax.
- The owner has a choice of the Cruze and Merlin wings to couple with their completed microlight base.
- The kit instructions are fully modelled in solidworks 3D providing superior clarity and precision in the assembly drawings.
- The stages have been designed to spread the capital outlay over time, and to allow the builder freedom to decide whether to install their own instrumentation, wiring looms and engine fitout components for the trike.



Clear assembly drawings



XT-582 OUTBACK KIT



STAGE 1

Part no: 11041

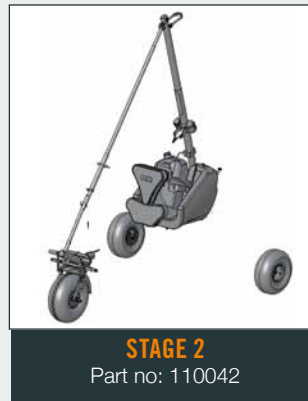

STAGE 2

Part no: 110042



STAGE 3 OUTBACK TRIM

Part no: 110043

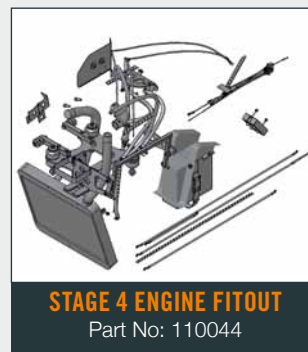

STAGE 4 ENGINE FITOUT

Part No: 110044



STAGE 5 INSTRUMENTATION

Part no: 110045

